

SPECIFICATION

DALI DT6 Series LED Driver

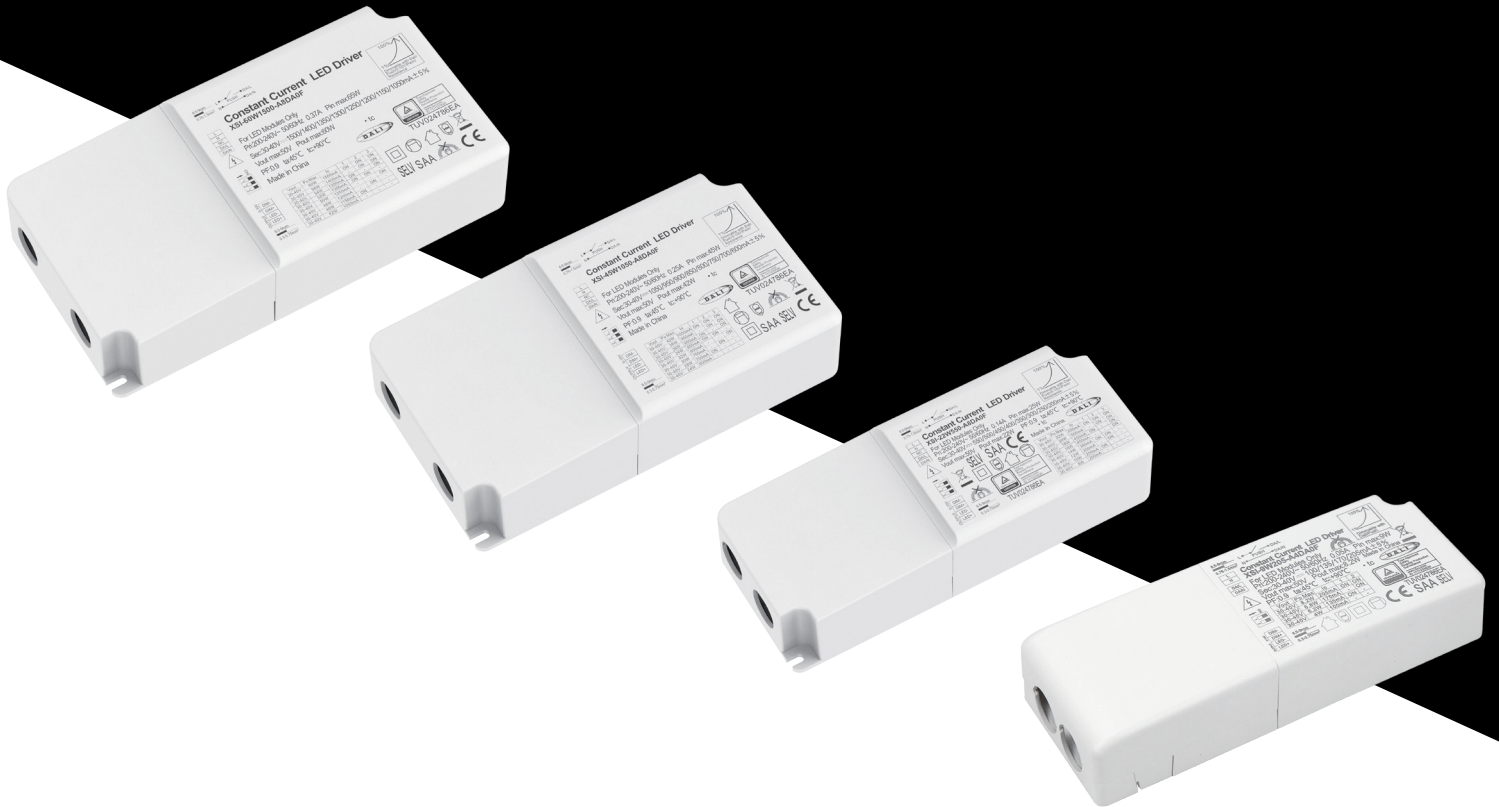

INTRODUCTION

The DALI series led driver provides the best compromise between an attractive price and qualified performance.

With a focus on application-related functions, the LED Driver range offers good quality and performance that ensures reliable operation of LED module.

Features

- Independent fixed output LED Driver
- Specific, optimized output current and voltage
- Output power dim, 4-60W
- Whole range are featured with flicker free performance
- Idea circuit design overcome luminarie flickering with voltage fluctuation.
- For luminaires of protection class I and protection class II
- Temperature protection as per EN / IEC61347
- Small, super compact dimensions
- Nominal life-time up to 50,000h
- DALI signal:16 bit Manchester Code Speed 1 % to 100 %



DALI 2.0

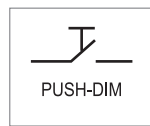

PUSH DIM



1-10V



TECHNICAL DATASHEET

Driver Datasheet (Dali-dimmable)					
Code		XSI-9W205-A4DA0F	XSI-22W550-A8DA0F	XSI-45W1050-A8DA0F	XSI-60W1500-A8DA0F
Input	Input Power	4-9W	8-22W	24-45W	45-60W
	Input Voltage	180-265V			
	Rated Input Voltage(V)	200-240V			
	Frequency	50/60HZ			
	Input Current	≤0.05A	≤0.14A	≤0.28A	≤0.37A
	Rated Input Current	≤0.04A	≤0.13A	≤0.25A	≤0.34A
	Power Factor (typ)	0.9			
	Total Harmonic Distortion(THD)	<20% @230V			
	Efficiency (typ)	≥78%	≥86%	≥88%	≥90%
	Inrush Current (Typ.)	18.8A/34.8uS	15.1A/113uS	16A/214uS	24.2A/326uS
	Max Circuit Breaker	Please refer to" Circuit breaker Specification"			
	Leakage Current	<0.5mA/240V			
	No Load Wattage	<0.5W @230V			
Output	Output Voltage Range	30-40V			
	Rated Output Current	100-205mA	200-550mA	600-1050mA	1050-1500mA
	Line Regulation	±5%			
	Open Circuit Voltage (max)	50V			
	Setup time(note1)	<1S @230V			
	Flickering Index(IEEESTd 1789)	3%(NO RISK)		6%(NO RISK)	6%(NO RISK)
Protection	Short Circuit Protection	Constant current limiting, recovers automatically after fault condition is removed			
	Over Voltage Protection	Shut down o/p voltage			
	Over Temperature Protection	Shut down o/p voltage, recovers automatically after temperature goes down			
Safety & EMC	Safety Standards	IEC/EN61347-1, IEC/EN61347-2-13, IEC/EN62384 independent,GB19510.14,GB19510.1 approved			
	Withstand Voltage	I/P-O/P:3.75KVac,<5mA 60S; I/P-FG:1.6KVac,<5mA 60S; O/P-FG:0.5KVac,<5mA 60S			
	Isolation Resistance	I/P-O/P: 500VDC, ≥100M Ω			
	Surge	IEC/EN61000-4-5(L-N:0.5KV,)		IEC/EN61000-4-5(L-N:1KV,)	
	EMC Emission	IEC/EN55015, IEC/EN61000-3-2			
	EMC Immunity	IEC/EN61000-4-2,3,4,5,6,8,11; IEC/EN61547			
Other	Dimension(L*W*H)	131.0*50.0*26.0mm	143.0*58.0*30.0mm	144.0*80.0*32.0mm	156.0*80.0*32.0mm
	Weight	0.09Kg	0.13Kg	0.20Kg	0.25Kg

DIMENSION

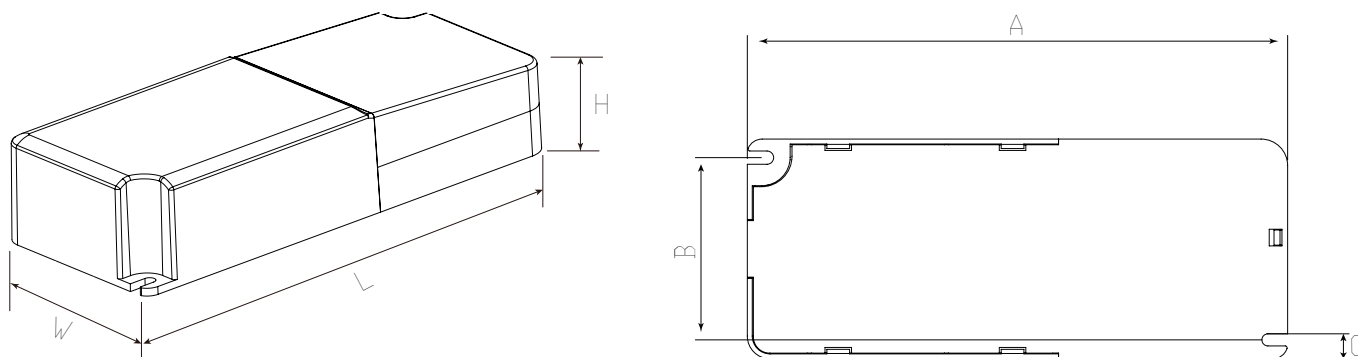

Code	Dimension(mm)						Product Weight (Kg)		Package weight (Kg)		Carton Size(cm)	Qty/CTN
	L	W	H	A	B	C	N.W/PC	G.W/PC	N.W/CTN	G.W/CTN		
XSI-9W205-A4DA0F	131.0	50.0	26.0	121.8	41.2	3.5	0.09	0.1	8.4	8.8	46.5*34.5*24.5	90PCS
XSI-22W550-A8DA0F	143.0	58.0	30.0	132.2	48.1	3.2	0.13	0.14	12.78	13.40	46.5*34.5*24.5	90pcs
XSI-45W1050-A8DA0F	144.0	80.0	32.0	133.4	69.4	3.2	0.20	0.21	18.63	19.25	46.5*34.5*24.5	90pcs
XSI-60W1500-A8DA0F	156.0	80.0	32.0	145.7	68.3	3.2	0.25	0.26	15.84	16.46	46.5*34.5*24.5	60pcs

CIRCUIT BREAKER SPECIFICATION

Circuit Breaker Specification								
Code	B10	B13	B16	B20	C10	C13	C16	C20
	10	13	16	20	10	13	16	20
XSI-9W205-A4DA0F	87	114	140	175	133	173	213	266
XSI-22W550-A8DA0F	21	27	33	41	34	44	55	68
XSI-45W1050-A8DA0F	21	27	33	41	21	35	43	53
XSI-60W1500-A8DA0F	19	24	30	38	20	25	31	39

DIP SWITCH TABLE

POWER FACTOR CHARACTERISTIC

Code	Vout	Po Max	Io	1	2
XSI-9W205-A4DA0F	30-40V	8.2W	205mA	ON	ON
	30-40V	6.8W	170mA	-	ON
	30-40V	5.2W	135mA	ON	-
	30-40V	4W	100mA	-	-

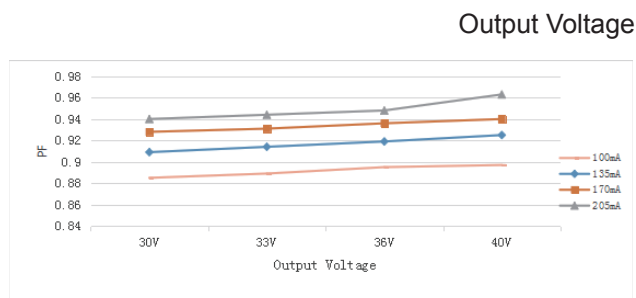

Code	Vout	Po Max	Io	1	2	3
XSI-22W550-A8DA0F	30-40V	22W	550mA	ON	ON	ON
	30-40V	20W	500mA	-	ON	ON
	30-40V	18W	450mA	ON	-	ON
	30-40V	16W	400mA	-	-	ON
	30-40V	14W	350mA	ON	ON	-
	30-40V	12W	300mA	-	ON	-
	30-40V	10W	250mA	ON	-	-
	30-40V	8W	200mA	-	-	-

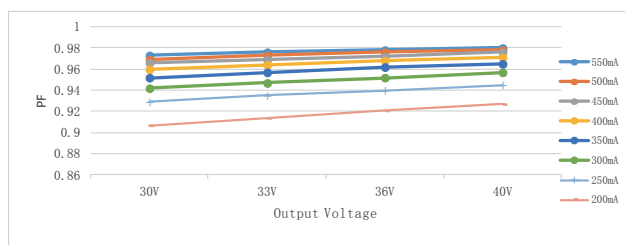

Code	Vout	Po Max	Io	1	2	3
XSI-45W1050-A8DA0F	30-40V	42W	1050mA	ON	ON	ON
	30-40V	38W	950mA	-	ON	ON
	30-40V	36W	900mA	ON	-	ON
	30-40V	34W	850mA	ON	ON	-
	30-40V	32W	800mA	-	-	ON
	30-40V	30W	750mA	-	ON	-
	30-40V	28W	700mA	ON	-	-
	30-40V	24W	600mA	-	-	-

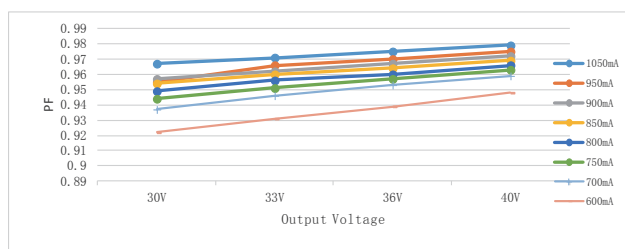

Code	Vout	Po Max	Io	1	2	3
XSI-60W1500-A8DA0F	30-40V	60W	1500mA	ON	ON	ON
	30-40V	56W	1400mA	-	ON	ON
	30-40V	54W	1350mA	ON	-	ON
	30-40V	52W	1300mA	ON	ON	-
	30-40V	50W	1250mA	-	-	ON
	30-40V	48W	1200mA	-	ON	-
	30-40V	46W	1150mA	ON	-	-
	30-40V	42W	1050mA	-	-	-

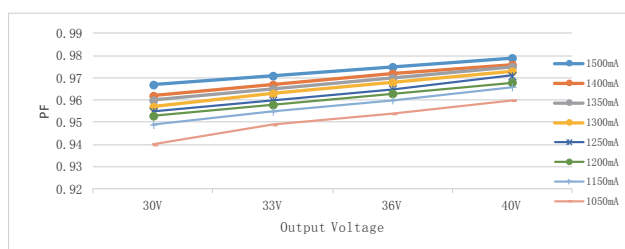

0-10V FUNCTION

1. 1-10V Mode Option

Under driver not in the 1-10V mode, it can achieve and keep 1-10V mode within 10 seconds by changing the voltage of the 1-10V interface, "High level-low level-high level-low level" or "Low level-high level-low level-high level" (high level is 8V-10V, low level is 0V-2V). When the DALI signal or Push Dimming signal is received, it will automatically switch to DALI or PushDim mode.

2. 1-10V Dimming Function

The 1-10V dimming function uses a linear output, and it has a smooth fade effect. When 1-10V interface voltage is less than 1.3V, output is 0%; when 1-10V interface voltage is over 9.5V, output is 100%; when 1-10V interface voltage is 1.3V-9.5V, linear output is 1%-100%.

PUSH DIMMING FUNCTION

1. Combines DALI and SwitchDim functions

The DALI and SwitchDim functions are automatically selected according to the voltage connected to DALI dimming interface. If the connected voltage is 9.5-22.5V DALI signal, it will be automatically selected as the DALI function. If the connected voltage is 100V~300V AC at 50Hz or 60Hz, it will be automatically selected as the PUSH dimming function.

2. Switch Dim Way

Short press: Press the reset button quickly and let go, the button will automatically restore the disconnected state, press button duration is 50ms-600ms.

Long press: Press the reset button quickly and keep it for more than 1000ms.

Dimming signal: Connect 50Hz or 60Hz AC100 ~ 300V voltage through a reset switch to connect the L and N terminals to the DALI interface.

3. Switch Dim Function

No	Function	Operation	Illustration
1	Memory	Power on	When the LED driver is powered on, it will restore the status before the LED driver was powered off; If the lamp is turned off before power off, it will still be off status after power on; If the lamp is 50% brightness before power off, then it will automatically restore to 50% brightness.
2	Turn on/off	Short press (< 0.6 s)	Brief push (< 0.6 s) switches to turn LED Driver ON and OFF; The dim level is saved at power-down and restored at power-up.
3	Dimming	Pushbutton held 1s-3s	When pushbutton is held, the LED lamps are dimmed; After repush, the LED lamps are dimmed in the opposite direction; Stop dimming when pushbutton released, dimming range 1-100%.
4	Synchronization	Long press 10s	In the same Switchdim system, 10s push to synchronize LED lamps to 50% dimming level; if LED lamps are in different dimming levels or opposite dimming directions (e.g. after a system extension)
5	Adjustable fade time	Long press 20s	The fade time decides dimming speed. The shorter the fade time, the faster the dimming speed; Fade time defaults 3s, long press 20s for fade time 6s and 100% brightness; Long press 10s, all lamps will be synchronized and turn into 50% brightness; Long press 20s again, the fade time go back to default setting; The brightness will remain 100% for long tim push butoon held.
6	Reset to factory settings	Long press 10s for 4 times	Factory default settings are restored by 4 times of 10s long press (the interval does not exceed 2s) Restore fade time, switch status, brightness, control mode, etc. to factory settings.

CIRCUIT DIAGRAM

No-load operation

In case of open circuit, protection will be activated, there will be 50V output voltage.

Glow wire test

According to EN 61347-1 with increased temperature of 960°C passed.

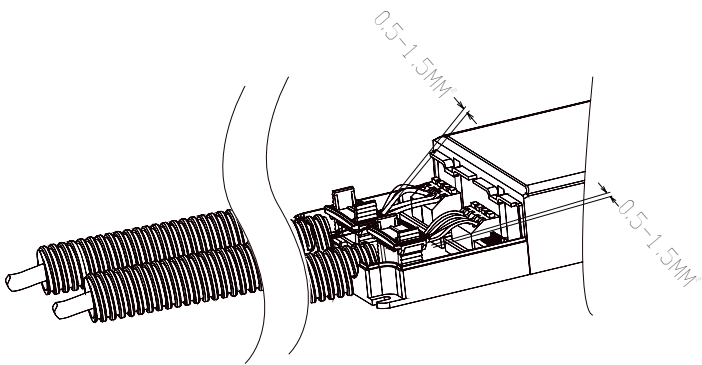

0-10V Dimming Connection

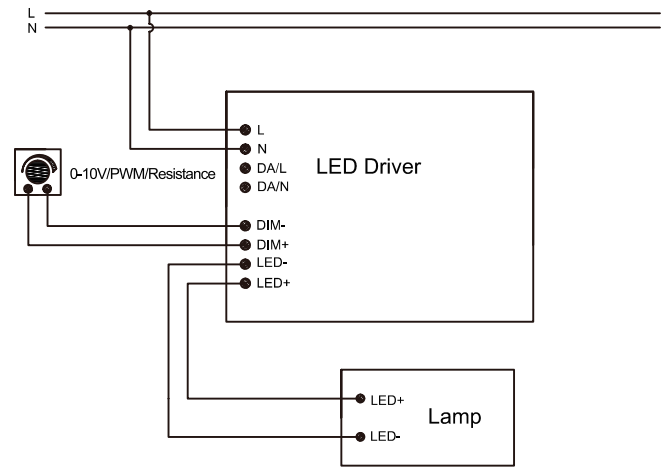

Dali Dimming Connection

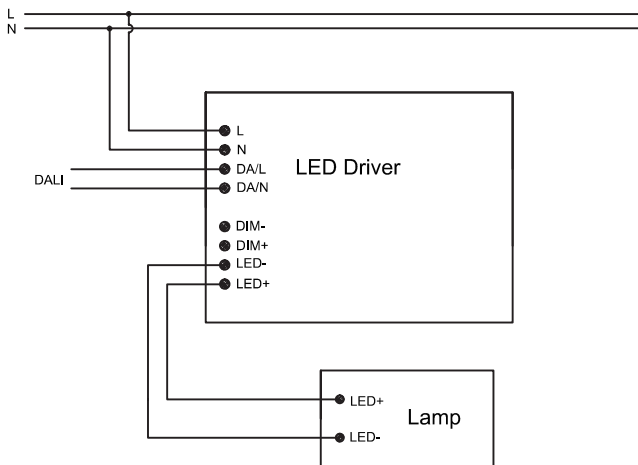

Push Dimming Connection

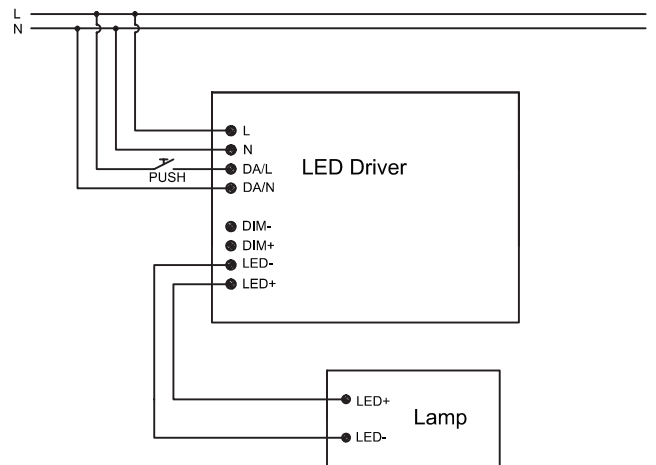

Up-shine Lighting Co.,Limited

www.upshine.com info@upshine.com TEL: +86 755 2919 7332

Add: 2nd building Dingfeng High-Tech Zone, Fuyuan 1st road, FuYong Sub-district, Bao'an, Shenzhen China

Up to Shine, there is life 光之上, 是生活