

Product Datasheet

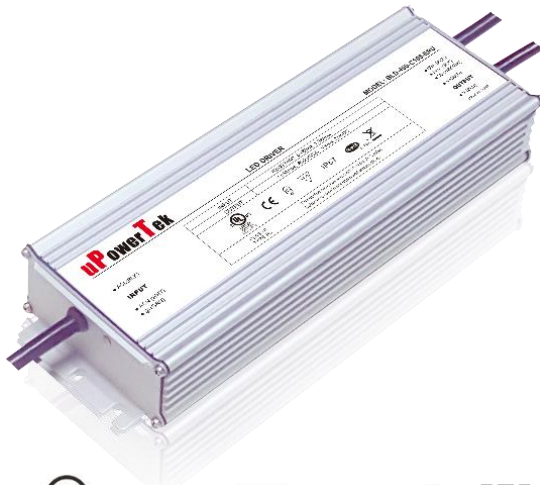

The global certified BLD-400-V series is a dual stage high efficiency smart LED driver. 2% minimum level and high frequency PWM output provides strobe flicker free user experience. 100khour long life and 8-year warranty provide high confidence to luminaire users. It supports not only traditional 4-in-1 control, but also DALI2.0, DMX and RS485 protocols. All around protections including digital OTP, SCP and OCP with auto-recovery secure 24hour non-stop operation for luminaires.

- Strip
- Light box
- Signage



- Features..... 2
- Model List..... 2
- Technical Data 3
- Dimming 3
- Safety/EMC Compliance..... 5
- Lifetime vs. Case Temperature..... 5
- Power Factor vs. Load 6
- THD vs. Load 6
- Efficiency vs. Load (24V Model) 7
- Inrush Current 7
- Dielectric Strength..... 8
- Tc Point..... 8
- Packaging Information 8
- Mechanical Design 9
- Revision History..... 15

■ Features

- Supply Voltage: 176-305Vac, 380Vac for 2 hours
- Great Surge Immunity 10kV
- Airset™ NFC Programmability
- PWM Output Frequency >1kHz
- 100,000Hour Life @ Tc=75°C
- 8 Year Warranty @ Tc<=75°C
- 0-10V/PWM/DALI2.0/Push (Switch) /DMX (RDM) Dimmable
- 2% Minimum Dimming Output
- Dim Off with 0.5W Standby
- 12V 300mA Auxiliary Power to Power Controllers and Fans (Optional)
- UL Class P, ENEC/CB/CCC SELV Output
- Safety according to EN 61347-1, 61347-2-3, 61347-2-13, 62384

■ Model List

Model Number	Input Voltage Range	Output Power	Output Voltage	Output Current Min	Output Current Max	Certification
BLD-500-V024-XYZ	176 ~ 305 Vac	500 W	24V	0	20A	UL/FCC/CB/ENEC/CCC/RCM/EAC
BLD-500-V048-XYZ	176 ~ 305 Vac	500 W	48V	0	10A	UL/FCC/CB/ENEC/CCC/RCM/EAC

XY=	Dimming Method	Programmable	12Vaux	Dim-off	Programming Range
NN	-	-	-	-	
TR	Timing	√	-	-	100%-115%Vo
DN	0-10V	-	-	<1.5W	
EN	0-10V	-	√	<0.5W	
ER	0-10V	√	√	<0.5W	100%-115%Vo
AN	DALI2.0	-	-	<1.5W	
MR	DMX	Set Address	-	<1.5W	

Z = U, UL cable with ground wire S, VDE cable/Class I D, VDE cable/Class II

Note: Dimmable Drivers Do NOT Support Switching DCDC Regulator as Load

■ Technical Data

Input Voltage	176~305Vac, 380Vac for 2 hours
Input Frequency	47~63Hz
Power Factor	>0.9@60-100%load, refer to PF vs. Load curve
THD	<15%@60-100%load, refer to THD vs. Load curve
Input Current	2.4Amax@220Vac & Full-Load
Inrush Current	See Inrush Current Section in the datasheet
Leakage Current	1mA max @277Vac 60Hz, UL8750,0.75mAmax @220Vac 50Hz, IEC61347-1
Input Under Voltage	Shut down and auto-restart
Input Over Voltage	*Optional: Shutdown @320Vac
Surge Protection	Line to line 6kV, line to ground 10kV, IEC 61000-4-5
Voltage Accuracy	±3%Vo
Setup Time	1.2s max.
Output Overshoot	10% Vo, max.
Output Over Current	120% Io, typ.
Short Circuit	Auto recovery. The output recovers when short is removed.
Over Temperature	Turn off the output when $T_c \geq 105 \pm 10^\circ\text{C}$; Auto Recovery When $T_c \leq 70 \pm 10^\circ\text{C}$
Operating Temperature	Case Temperature $T_c = -40^\circ\text{C} \sim +90^\circ\text{C}$; 10%RH~100%RH
Storage Temperature	$-40^\circ\text{C} \sim +85^\circ\text{C}$; 5%RH~100%RH
MTBF	≥280,000 hours, 75°C case temperature (MIL-HDBK-217F)
Lifetime	≥100,000 hours, 75°C case temperature, refer to life vs. Tc curve
Case Temperature	90°C max, marked in the Tc point of label
Dimensions	8.82x3.54x1.63 by inch (body), 9.88x3.54x1.63 by inch (endcaps included) 224 x 90 x 41.5 by mm (body), 251 x 90 x 41.5 by mm (endcaps included)
Net Weight	1600g
Packing	See Package Information Section in the datasheet

Notes: Unless specified, all the test results are measured in 25°C room temperature.

■ Dimming

Parameter	Min.	Typ.	Max.
Vdim Sourcing Current	100uA	150uA	200uA
Vdim Allowed Input Voltage	-20 V		20 V
0-10V Dimming Range	2% (Vdim=1V)	Linear	100% (Vdim=9~10V)
PWM Dimming Range	2% (Duty=10%)	Linear	100% (Duty=90-100%)
Dim off threshold	0.4V or 4%	0.5V or 5%	0.6V or 6%
Dim on threshold	0.6V or 6%	0.7V or 7%	0.8V or 8%
PWM High	3.8V		10V
PWM Low	0V		0.6V
PWM Frequency	300Hz		2kHz
External PWM Controller Current Sinking Capability	300uA		

500W, 200-277Vac Input Constant Voltage LED Driver

DALI Interface Standard	IEC62386, part 101,102,207		
DA1,DA2 High Level	9.5	16	22.5
DA1,DA2 Low Level	-6.5	0	6.5
DA1,DA2 Current	0		2mA

Dimming Curve

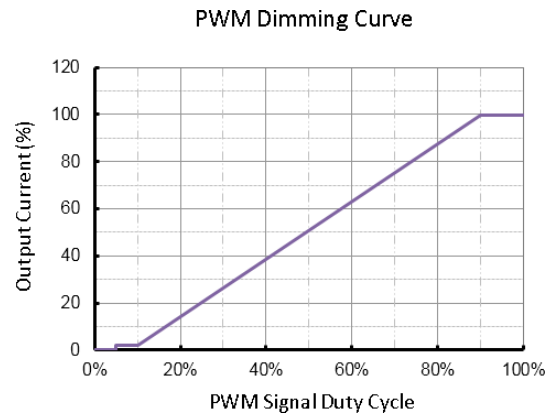
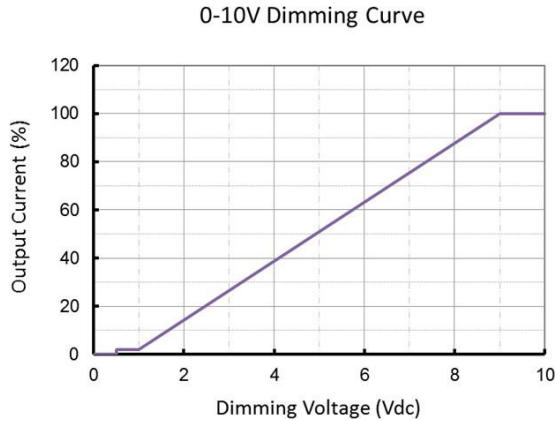

Dimming Wiring

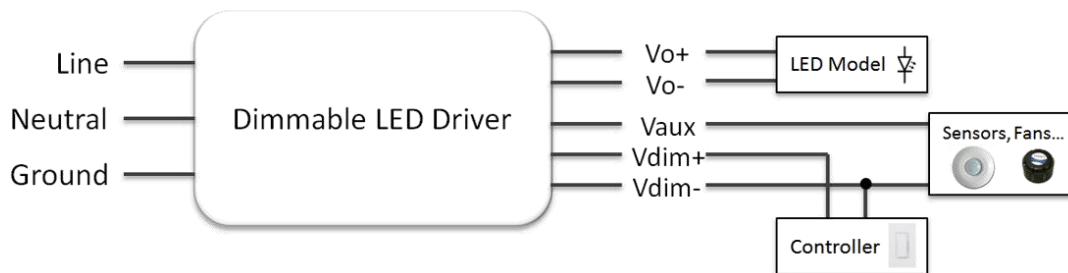

Push (Switch) Dim

A short press (50-600 ms) switches the device on or off
 A long press (> 600 ms) fades the connected operating device alternately up and down (between 2 and 100%).
 Up and down slew rate is 20%/s.
 Long push for 15s to synchronize.

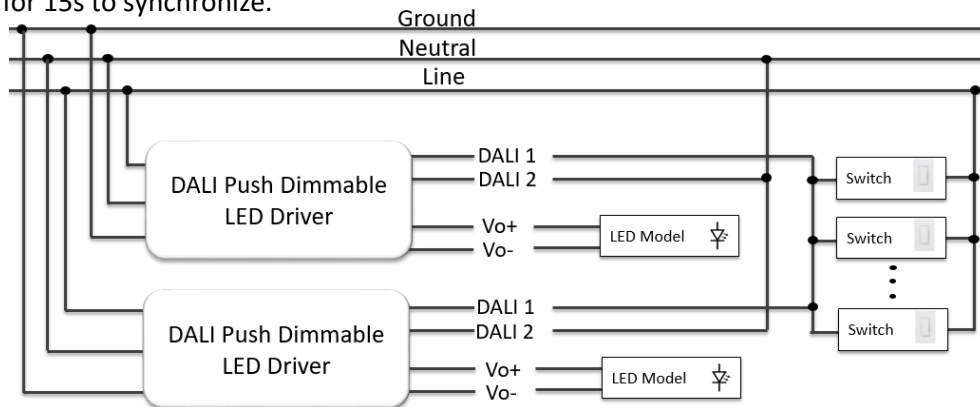

■ Safety/EMC Compliance

Safety Standard	Description
UL8750	Light emitting diode(LED) equipment for use in lighting products
UL1012	Power units other than class 2
IEC 61347-1	Lamp control gear Part 1: general and safety requirements
IEC 61347-2-13	Lamp control gear Part 2-13: particular requirement for d.c. or a.c. supplied electronic control gear for LED modules
EMI Standards	Description
IEC 55015	Conducted emission test & radiated emission test
IEC 61000-3-2	Harmonic current emissions; Class C
IEC 61000-3-3	Voltage fluctuations & flicker
FCC Part 15	ANSI C63.4:2009 Class B
EMS Standards	Description
IEC 61000-4-2	Electrostatic discharge (ESD): 8 kV air discharge, 4 kV contact discharge
IEC 61000-4-3	Radio frequency electromagnetic field susceptibility test (RS)
IEC 61000-4-4	Electrical fast transient (EFT)
IEC 61000-4-5	Surge immunity test
IEC 61000-4-6	Conducted radio frequency disturbances test (CS)
IEC 61000-4-8	Power frequency magnetic field test
IEC 61000-4-11	Voltage dips
IEC 61547	Electromagnetic immunity requirements applies to lighting equipment

■ Lifetime vs. Case Temperature

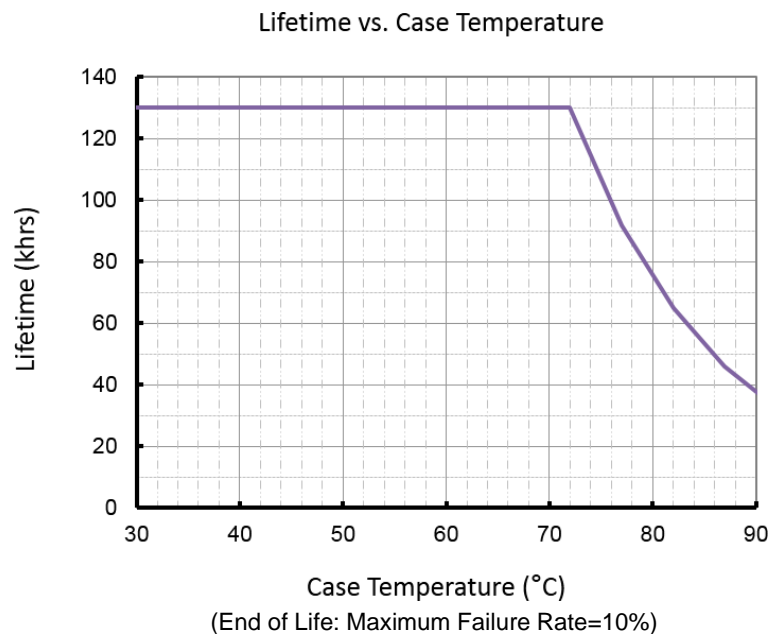

■ Power Factor vs. Load

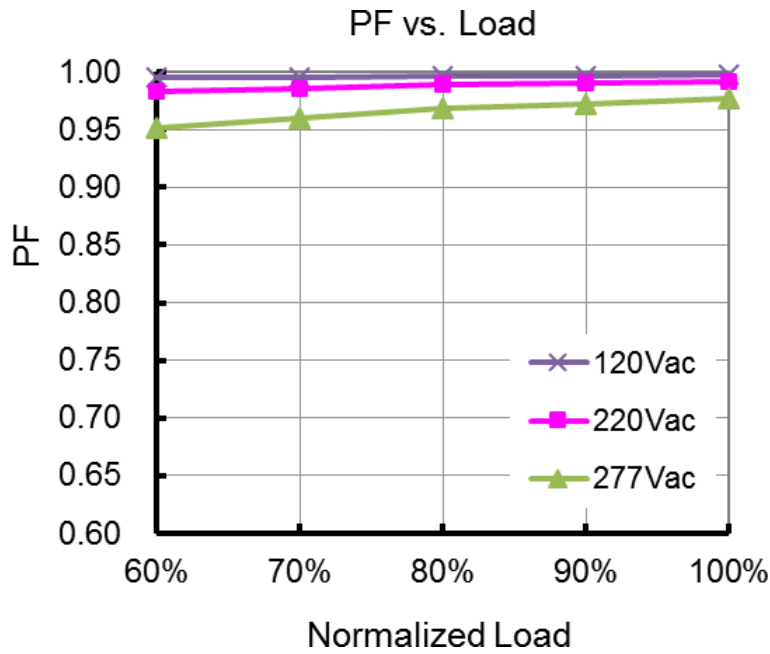

■ THD vs. Load

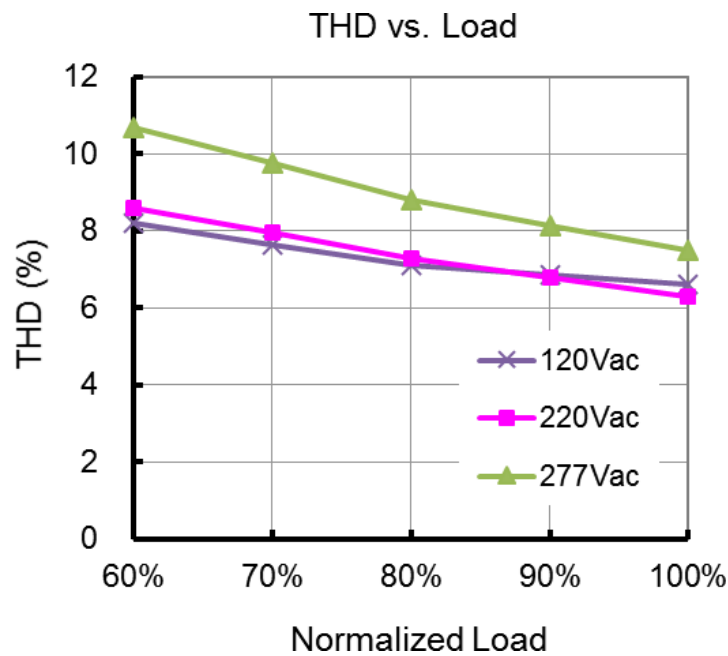

■ Efficiency vs. Load (24V Model)

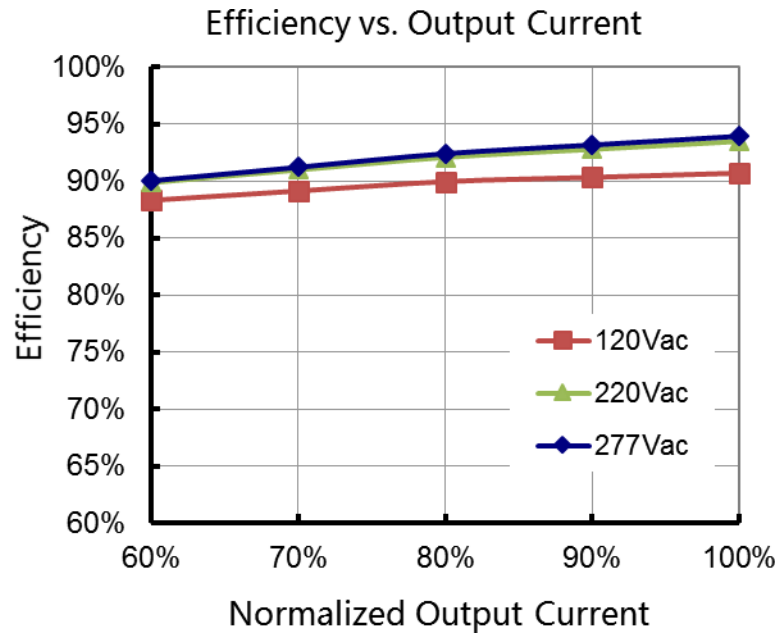

■ Inrush Current

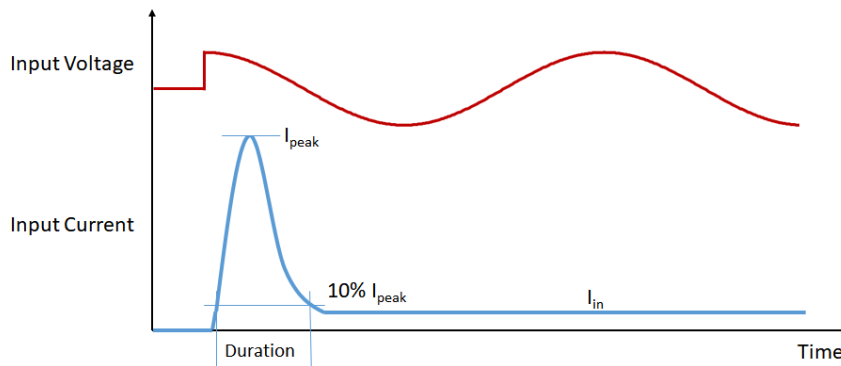

Input Voltage	I_{peak}	Duration
120Vac	18.0A	5.32mS
220Vac	30.8A	5.24mS
277Vac	42.2A	5.08mS

Please contact with us for MCB calculation and waveforms.

■ Dielectric Strength

Unit: Vac	Input	Output	Dimming	Case
Input	-	3750	3750	1554
Output	3750	-	-	1554
Dimming	3750	-	-	1554
Case	1554	1554	1554	-

■ Tc Point

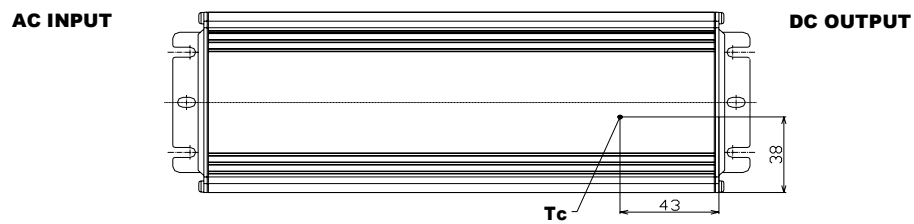

■ Packaging Information

Typical Carton Dimension(L×W×H)	490×370×125 mm
Positioning plate	2pcs/carton
Shield Board	1pcs/carton
LED Drivers	6pcs/carton

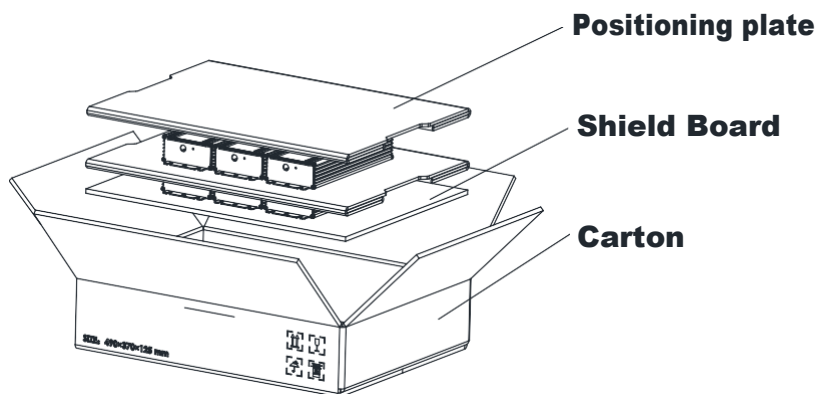

■ **Mechanical Design**

-BLD-500-Vxxx-NNU (UL Cable) 48V model

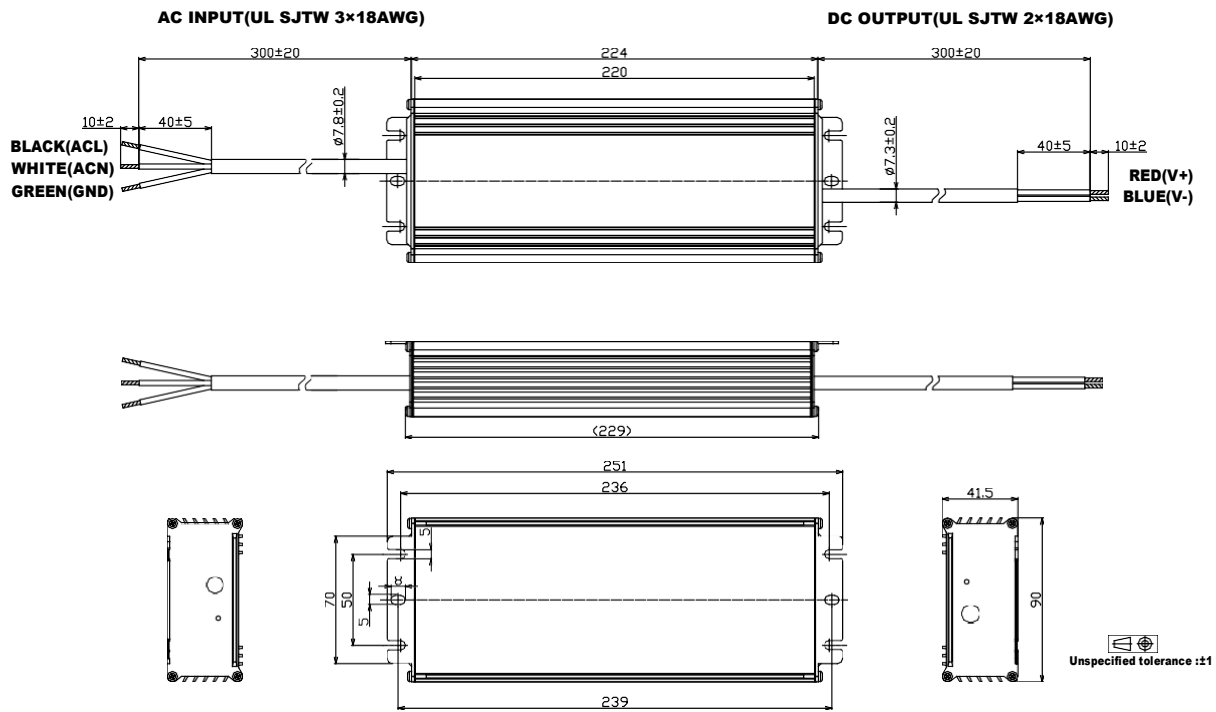

-BLD-500-Vxxx-NNU (UL Cable) 24V model

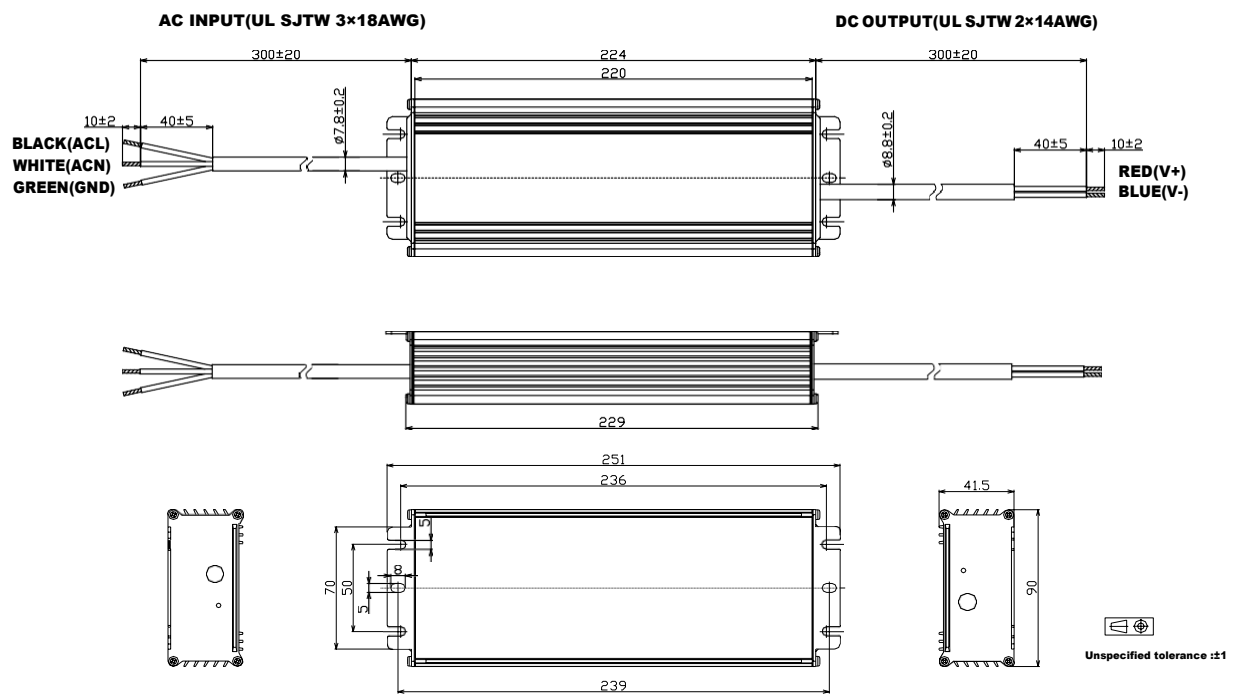

500W, 200-277Vac Input Constant Voltage LED Driver

-BLD-500-Vxxx-ENU (UL Cable) 48V model

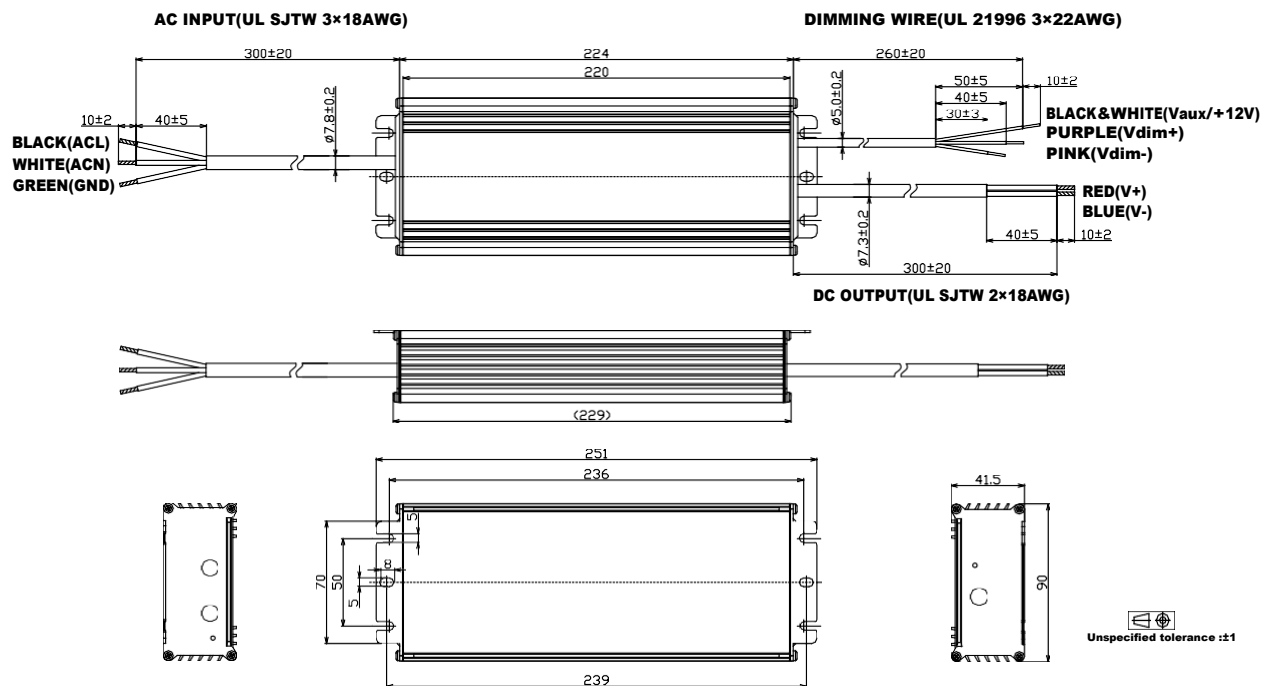

-BLD-500-Vxxx-ENU (UL Cable) 24V model

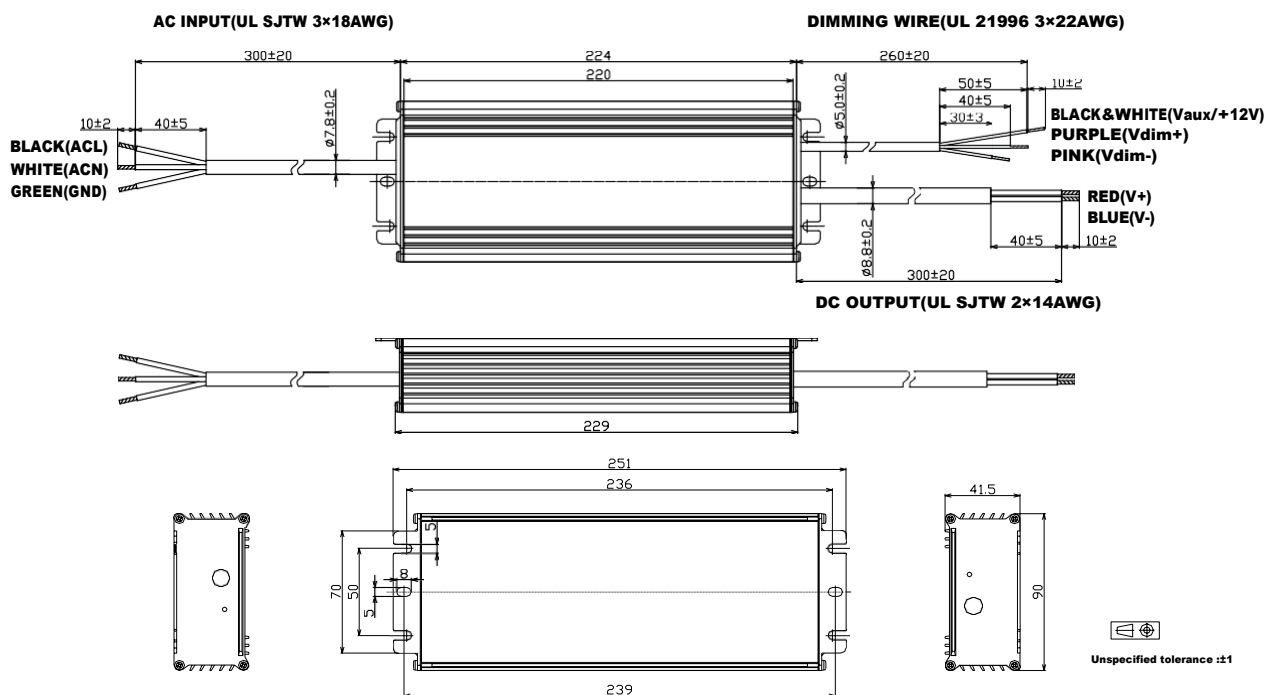

-BLD-500-Vxxx-ANU (UL Cable) 48V model

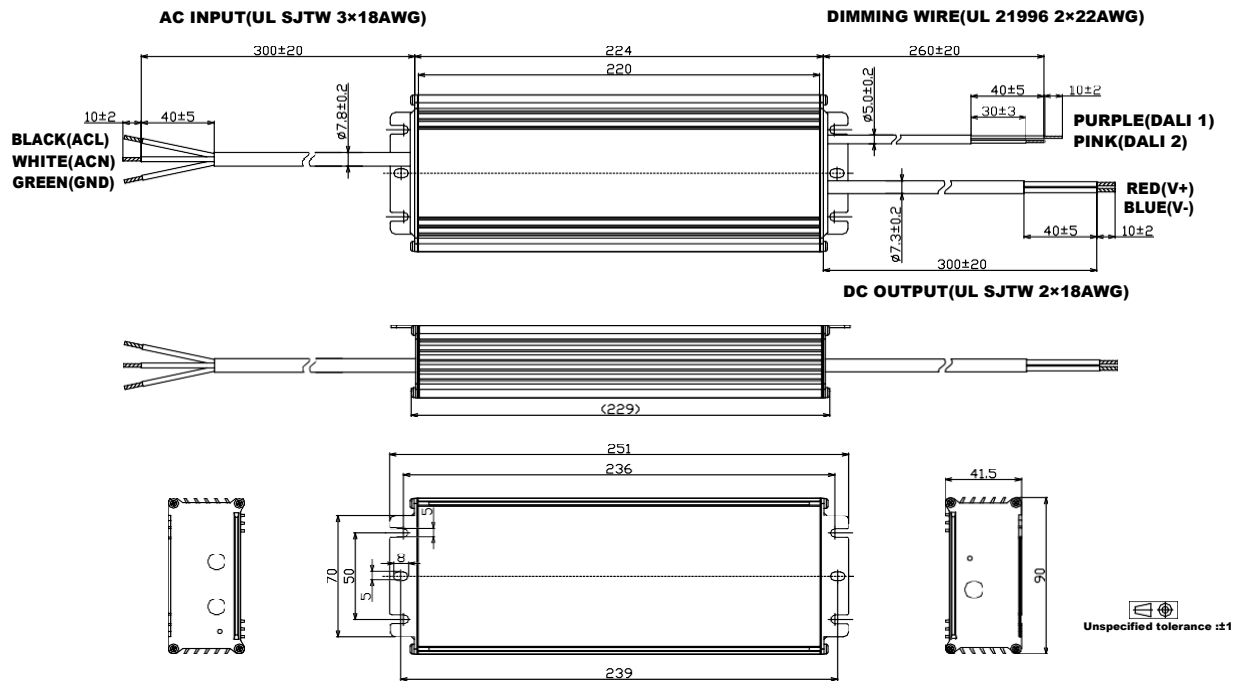

-BLD-500-Vxxx-ANU (UL Cable) 24V model

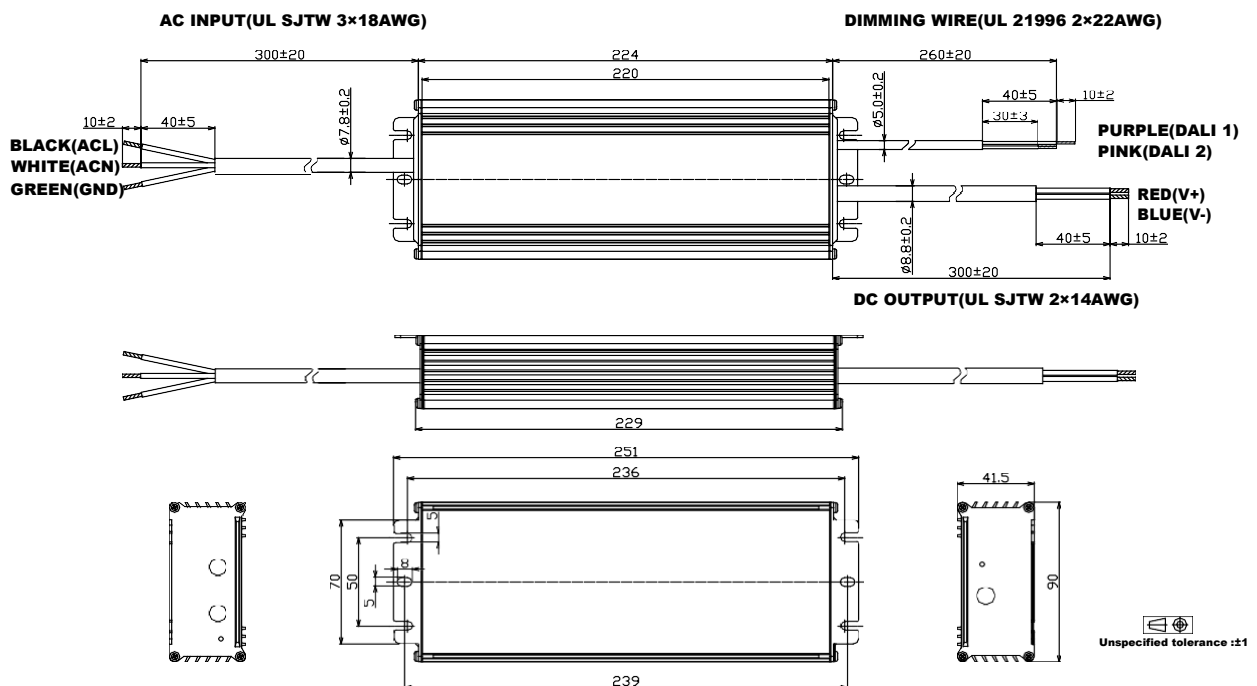

500W, 200-277Vac Input Constant Voltage LED Driver

- BLD-500-Vxxx-NNS (VDE Cable) 48V model

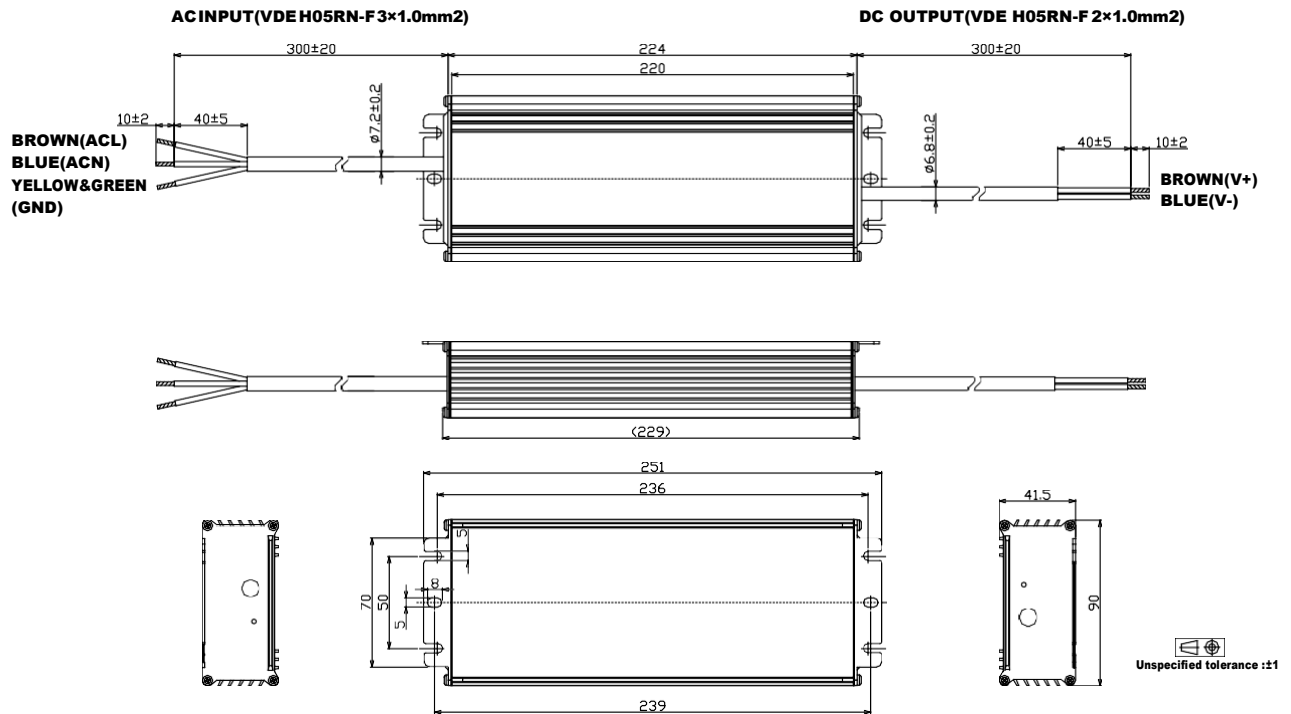

- BLD-500-Vxxx-NNS (VDE Cable) 24V model

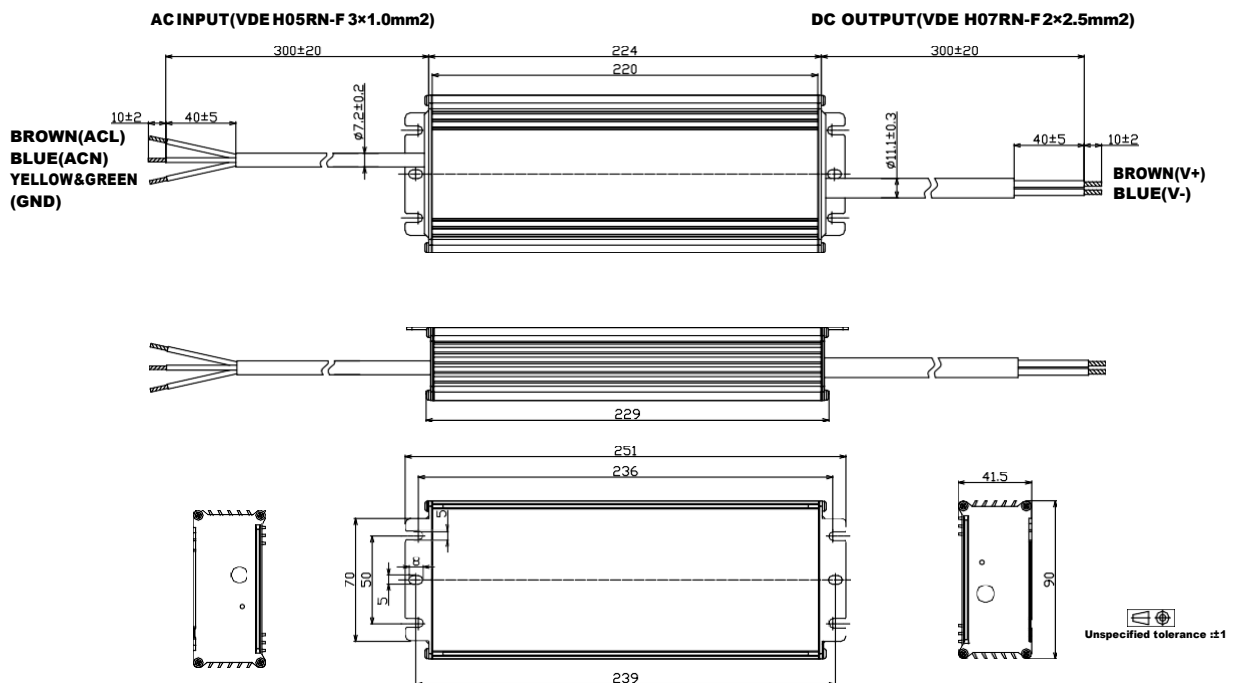

500W, 200-277Vac Input Constant Voltage LED Driver

-BLD-500-Vxxx-ENS (VDE Cable) 48V model

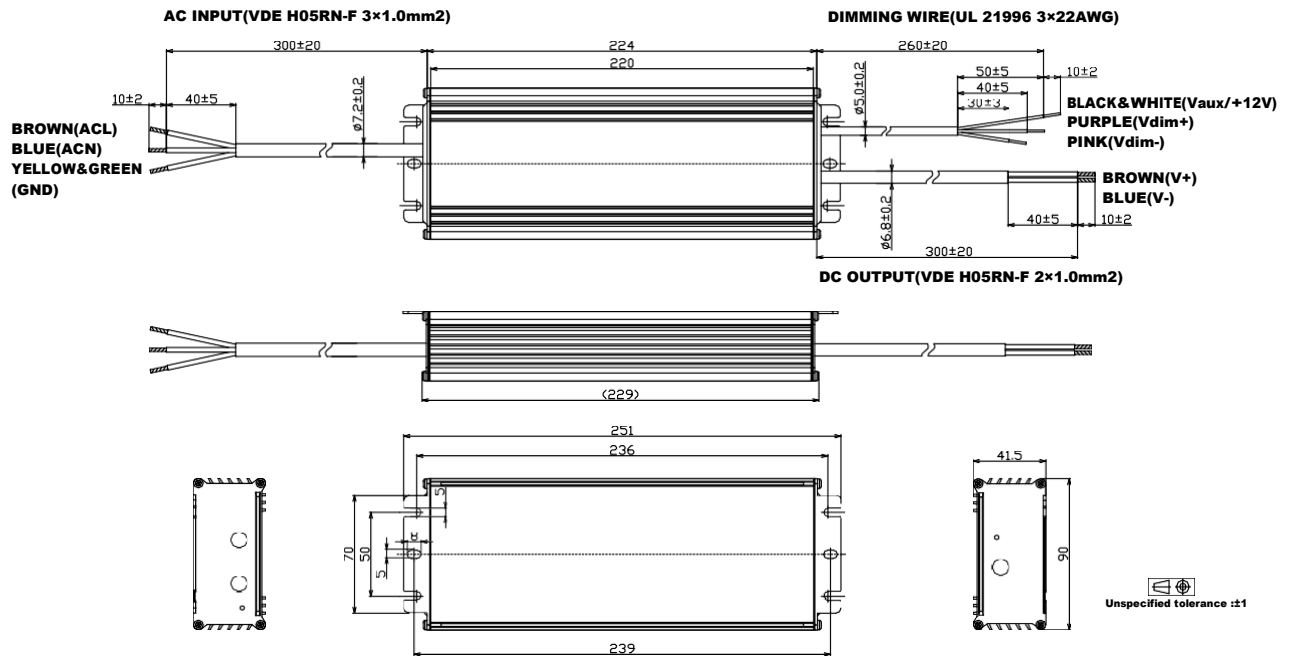

-BLD-500-Vxxx-ENS (VDE Cable) 24V model

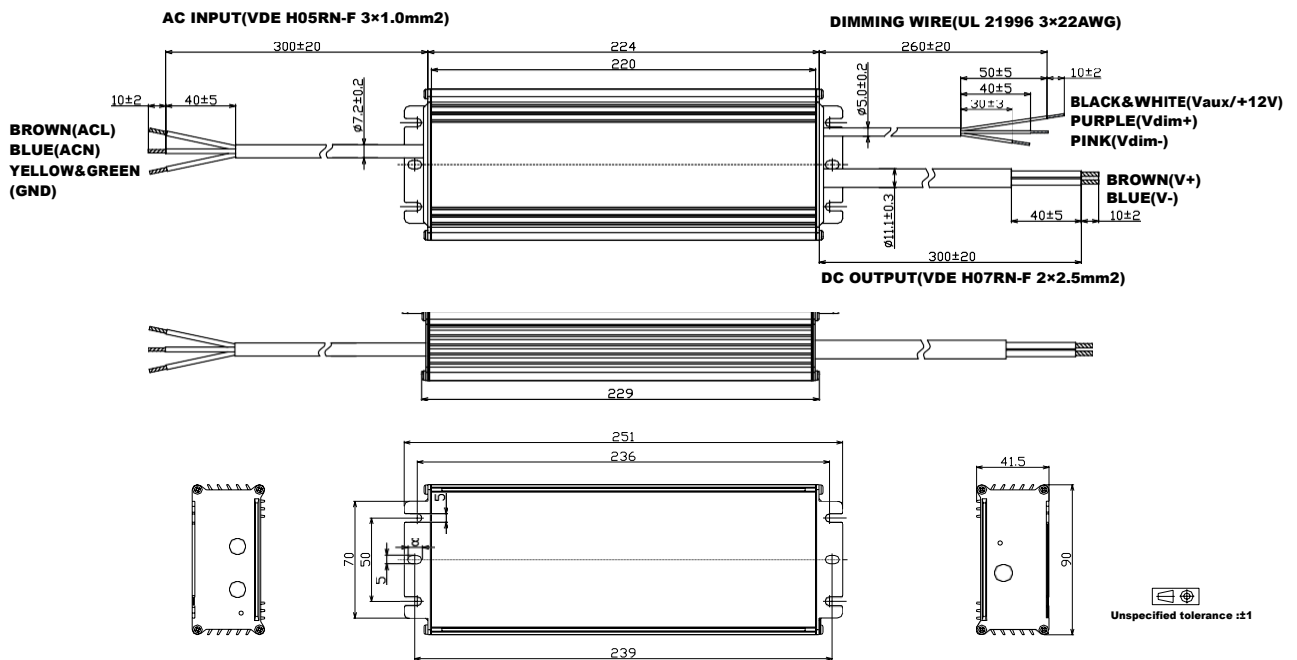

500W, 200-277Vac Input Constant Voltage LED Driver

- BLD-500-Vxxx-ANS (VDE Cable) 48V model

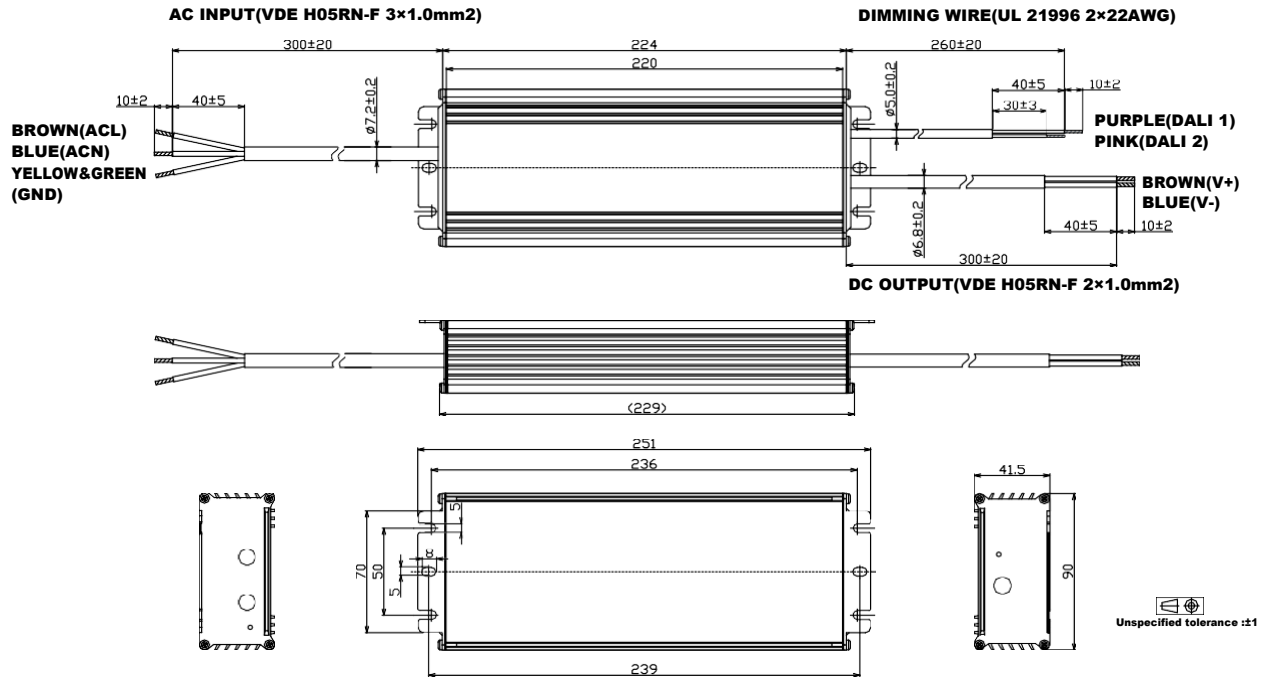

-BLD-500-Vxxx-ANS (VDE Cable) 24V model

