

5 Channel Constant Voltage Power Repeater

Model No.: EV5

5 Channel/PWM signal input/Constant voltage output/3KV optoelectronic isolation



CE RoHS LVD

Features

- 12-24V constant voltage power repeater.
- 5 channel, 5A per channel.
- To receive PWM signal control.
- Power repeater in series or in parallel to expand output unlimitedly.
- Apply to RGB+CCT constant voltage LED strip or module.

Technical Parameters

| Input and Output | |
|------------------|------------------|
| Input voltage | 12-24VDC |
| Input current | 25.5A |
| Input signal | PWM |
| Output voltage | 5 x [12-24]VDC |
| Output current | 5CH, 5A/CH |
| Output power | 5 x [60-120]W |
| Output type | Constant voltage |

| Environment | |
|-------------------------|-------------------|
| Operation temperature | Ta: -30°C ~ +55°C |
| Case temperature (Max.) | Tc: +85°C |
| IP rating | IP20 |

| Safety and EMC | |
|----------------------|---------------------|
| EMC standard (EMC) | EN301 489, EN 62479 |
| Safety standard(LVD) | EN60950 |
| Certification | CE, EMC, LVD |

| Warranty and Protection | |
|-------------------------|------------------|
| Warranty | 5 years |
| Protection | Reverse Polarity |

| Weight | |
|--------------|---------|
| Net weight | 0.243kg |
| Gross weight | 0.264kg |

Mechanical Structures and Installations

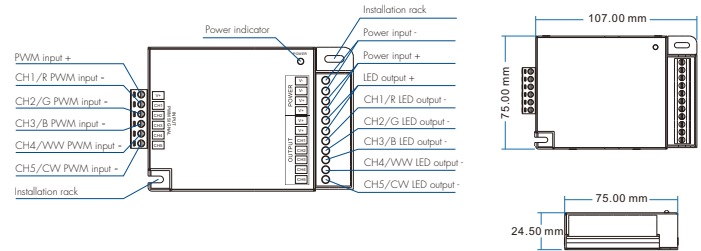

Wiring Diagram

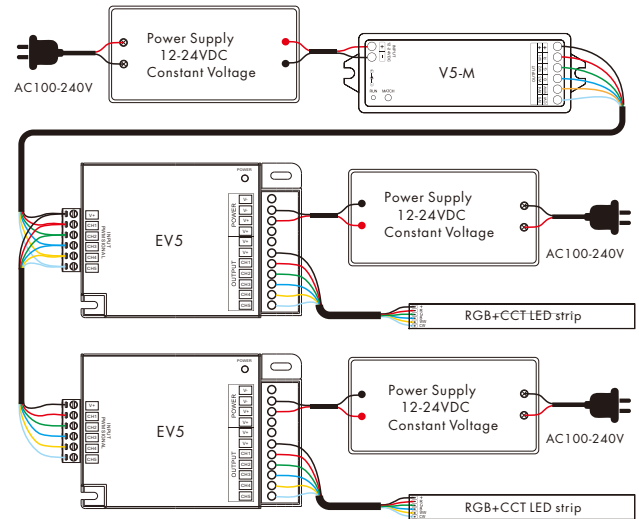

Malfunctions analysis & troubleshooting

| Malfunctions | Causes | Troubleshooting |
|--|--|---|
| No light | 1. No power. 2. Wrong connection or insecure. | 1. Check the power. 2. Check the connection. |
| Wrong color | 1. Wrong connection of R/G/B/WW/CW wires. | 1. Reconnect R/G/B/WW/CW wires. |
| Uneven intensity between front and rear, with voltage drop | 1. Output cable is too long. 2. Wire diameter is too small. 3. Overload beyond power supply capability. 4. Overload beyond controller capability. | 1. Reduce cable or loop supply. 2. Change wider wire. 3. Replace higher power supply. 4. Add power repeater. |

Safety & Warnings

1. The product shall be installed and serviced by a qualified person.
2. This product is non-waterproof. Please avoid the sun and rain.
3. Good heat dissipation will prolong the working life of the controller, Please ensure good ventilation.
4. Please check if the output voltage of any power supplies used comply with the working voltage of the product.
5. Ensure all wire connections and polarities are correct and secure before applying power to avoid any damages to the LED lights.
6. If a fault occurs please return the product to your supplier. Do not attempt to fix this product by yourself.