

SIGN MODULES

6x 2835 LED | 3.0W

Edge-Lit Module

LL-SM-EL3-10K

LINEAR LUX
LED LIGHTING SOLUTIONS

Applications

- Double sided sign backlighting
- Outdoor lighting for advertising

Features

- Ultra narrow beam angle allows for modules to be mounted to the perimeter of the frame shining inwards
- High performance Samsung 2835 LEDs
- Efficient heat design, requires no heat-sink
- Safe low voltage
- Double sided tape and screw mounting

Electrical Data

Voltage	12.0 VDC
Wattage per module	3.0 W
Current per module	250mA / 12 V

LED Data

LED type	2835
Manufacturer	Samsung
Quantity of chips per LED	1
Quantity of LEDs per module	6

Photometric Data

Colour temperature	9,000 ~ 10,000°K
Colour rendering index Ra	>80
Luminous flux per module	240 lm
Luminous efficacy	80 lm/W
Beam angle	40°
Dimmable	1 ~ 100%

Construction / Protection Data

Package	ABS
Mounting	Fitted with double sided tape 3M Screw holes
IP rating	IP68
Operating temperature	-30 ~ +70 C°
Storage temperature	-40 ~ +75 C°

Dimensions (module)

Length	43.0mm
Width	43.0mm
Height	19.0mm

Dimensions (string)

Wire between modules	150.0 mm
Length	7.8 m (50 modules)

Lifetime

Lifespan (L70)	>50,000 hours
----------------	---------------

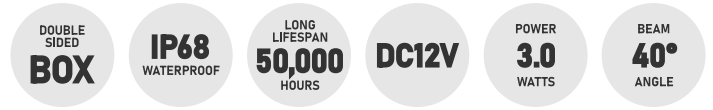

Dimensions

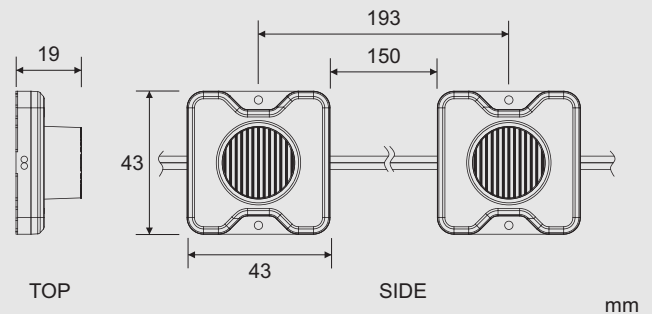

Light Distribution Diagram

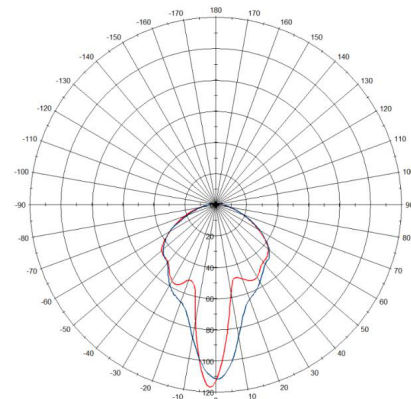

Testing environment temperature = 25°C ±2.0°

SIGN MODULES

6x 2835 LED | 3.0W

Edge-Lit Module

LL-SM-EL3-10K

Wiring

No more than 10 modules can be wired in a serial connection

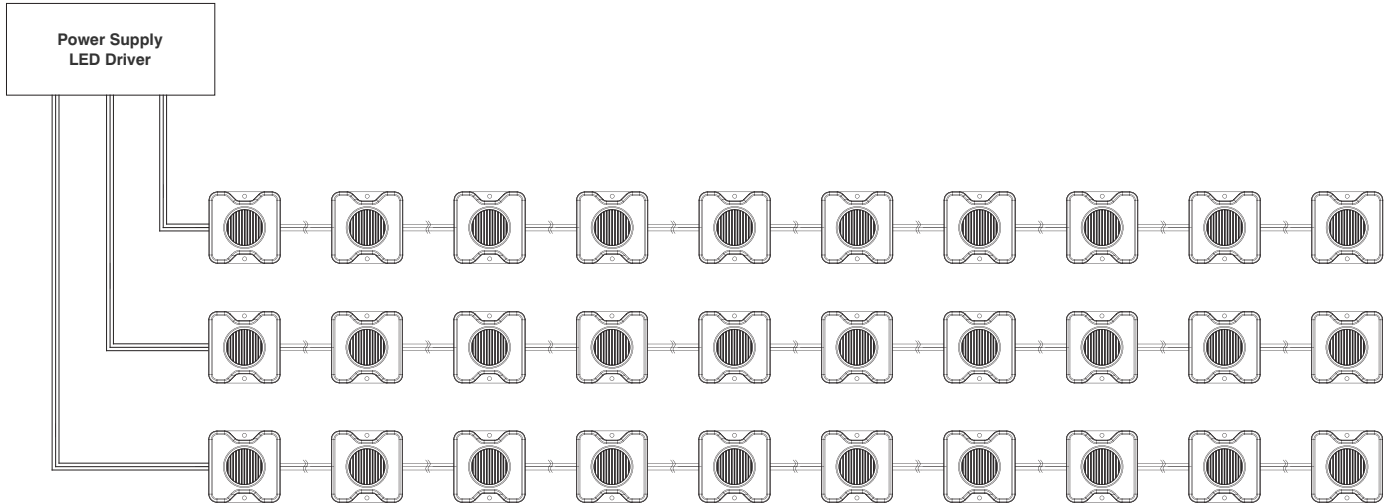

Efficiency

The use of edgelit modules versus backlight modules is more efficient both in terms of the number of modules required and overall power consumption. The below examples show scenarios for both Letter signs and Lightboxes.

Letter Comparison

1.2W backlight module vs 1W edgelit module

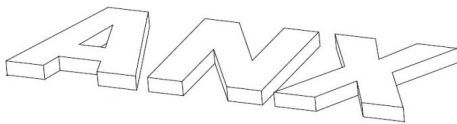

Overall Sign Dimensions

Length	Width	Height
300cm	100cm	12cm

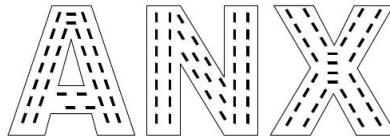

1.2W Backlight Module

Module Pitch	Quantity	Power Consumption
90mm	104	125W



1W Edgelit Module

Module Pitch	Quantity	Power Consumption
120mm	64	64W

Lightbox Comparison

1W backlight module vs 3W edgelit module

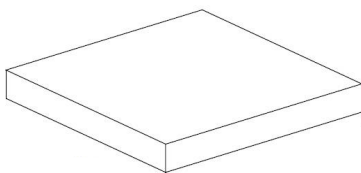

Overall Sign Dimensions

Length	Width	Height
100cm	100cm	12cm

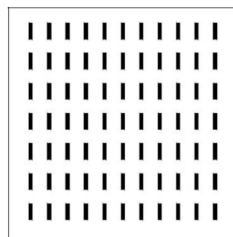

1W Backlight Module

Module Pitch	Quantity	Power Consumption
90mm	80	80W

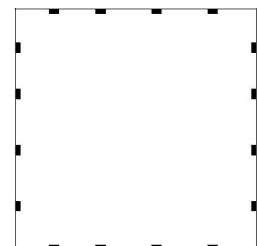

3W Edgelit Module

Module Pitch	Quantity	Power Consumption
150mm	16	48W